

**Delux**  
Smart Ice Solutions

# AUTOMATIC ICE DISPENSERS

installation use and  
servicemanual



APPLIES MODEL  
DXL-15 / 25

Purified Clean Water.  
Crystal Clear Ice.

**03** Part I  
Features

Part II  
Prior To Use

**04** Part III  
Structure Diagram

Part IV  
Operation

**05** Part V  
Maintenance

**06** Part VI  
Technical Data

Part VII  
Circuit Diagram

**07** Part VIII  
Trouble Shooting  
And Solutions

Part X  
Problem Indicator  
Light Reference

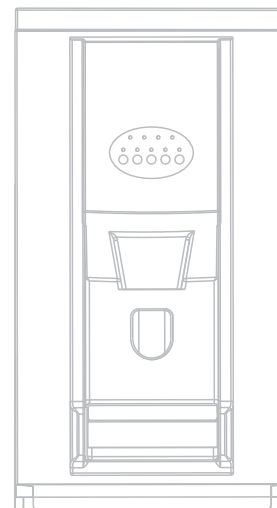

**ICE DISPENSERS**

ice is always there  
where or when you need

## PART I FEATURES

Delux automatic ice dispenser has large storage capacity, smooth ice dispensing and fast ice cycle. The ice produced is crystal clear crescent shape. Microchip controlled system ensures fast ice supply, consistent ice and constant water flow. During the ice manufacturing cycle, a green indicator will turn on ( ice being made ) . When the storage bin is full, the green indicator will turn off and a yellow indicator will turn on. The ice storage bin is fully insulated with a high density foam structure, which maintains excellent thermal insulation, resulting in limited melting and longer storage of ice cubes.

## PART II PRIOR TO USE

1. Do not tilt the machine past 45° angle while in transit to avoid damaging compressor and cooling system..
2. The ice dispenser has a self-auto-cleaning function, this limits contamination if the machine is not being used all the time. However, upon installation or after long period of non-usage, we strongly suggest that the ice dispenser be set up as water dispense status to clean machine first ("Water" indicator is on, press the button and use a glass to collect water.) Flushing the water line of at least 2 glasses before drinking is recommended after set up.
3. Do not run the appliance near explosives, highly flammable material, gas lines or other heat sources. Install the machine on

horizontal, even, stable surface, leaving at least 6 inches / 150mm of free space for proper air circulation.

4. Adjust the feet to level the ice dispenser, otherwise the water level will not be even affecting the ice shape. Please let the unit stand upright for 12 hours before connecting the appliance to the power supply.
5. Make sure the water drain pipe is lower than the machine, allowing proper flow of waste water to the drain, Gravity Drain .
6. Rating voltage and frequency should be: 240V, 50Hz.
7. The cable cord plug should be > 6A, 0.75mm<sup>2</sup>, single core or multi-core, with 5A fuse.
8. Connect to a separate earthed socket .
9. In order to avoid any damage, power cord

should be attached to the machine by the installer or qualified technician.

10. If in proximity of children, please keep close supervision to avoid any accidents.

11. Do not handle machine with wet hands or feet.

12. Do not use the appliance if the cable or the plug has any damage.

## PART III STRUCTURE DIAGRAM

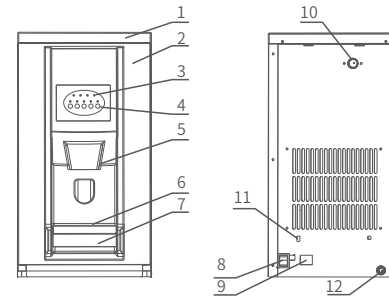

1. Top Cover	7. Water Tray
2. Front Panel	8. Power Switch
3. Indicators	9. Power Cable
4. Function Keys	10. Water Inlet Connector
5. Ice / Water Outlet	11. Power Cable Clamp
6. Water Tray Lid	12. Water Drain Connector

## PART IV OPERATION

1. Remove the machine from package and take out the accessories, including user manual, water inlet pipe, water drainpipe, etc.
2. Place the machine on a horizontal, even, stable surface, leaving at least 6 inches /150mm clearance of walls for proper air ventilation.
3. Connect the water drain pipe to the water

drainage connector on the rear of the machine, and insert the other end of the water drainpipe to a drain.(Drain must be lower than the machine )

4. Connect the water inlet pipe to the water supply (water inlet connector is a male pipe thread of 3/4 inch). Water pressure should be a minimum of 14.2PSI / 1 Bar and a maximum of 113.6PSI/ 8 Bar Connect the other end of water inlet pipe

to the rear of machine. Sealing rings should be placed on both sides of water inlet pipe during connection.

- After plugging in the power connection, press the power switch on the rear of the machine. "Power" indicator on the operational panel will light up, and ice machine begins cycle. The process from water filling, ice making, ice releasing, and ice storage is automatically controlled by microchip system, and the ice making cycle starts automatically and runs continuously. When the ice bin is full, "Ice full" indicator light on the operational panel will light up and the machine will

stop producing until ice is removed. When there is a shortage of water or water supply failure, "Power" indicator light on the operation panel will turn on, and the ice dispenser automatically stops working.

- Press the option buttons to select ice or water. Then press the function button to open ice/water outlet and the ice or water will dispense automatically, as per your selection.
- When the ice cubes reach the "Ice Full" sensor, the machine will stop producing. After ice is dispensed below the sensor, the ice production will resume.

## PART V MAINTENANCE

- Periodically check the water inlet and water outlet to prevent potential leaking.
- If machine will not be used over extended period of time, we strongly recommend disconnecting it from the water supply and draining all the water in the water lines by pressing the function button for about 10 seconds.
- Do not pull any lines or cords when plugging or unplugging power. Use as directed with your hand on the plug.
- Always disconnect power before cleaning. Use soft fabrics with neutral and nonabrasive cleaner, then rinse the machine with clean water and wipe dry. Do not use hot water, oxidizing cleaner, acid, benzene or high oxidizing organic cleaner.

## PART VI TECHNICAL DATA

(Tested under 15°C ambient temperature and 10°C water temperature)

Model	Ice Make Capacity (Kg/24h)	Rated Power(W)	Rated Voltage(V)	Refrigerant R134a (g)	NW/GW (Kg)	Machine Dimension (mm)
DLX-15	≥14	180	220-230	135	28/ 30	585 ×310×735
DLX-25	≥24	240	220-230	155	31/36	585×430×905

Protection against Electric Shock: I type.

\*We reserve the right to make changes in specifications and design without prior notice.

## PART VII CIRCUIT DIAGRAM

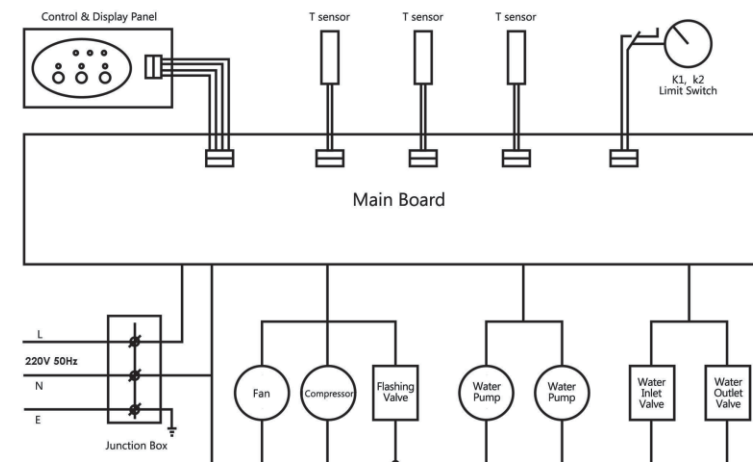

## PART VIII

### TROUBLE SHOOTING AND SOLUTIONS

Trouble shooting: If a problem arise during operation of your machine, please follow the table below before calling service.

Issue	Reasons	Solutions
Ice dispenser is not producing ice	1.The voltage is lower than recommended 2.Ambient temperature is higher than 45°C	1. Stop the machine and do not restart until the voltage is normal. 2. Restart the appliance when the ambient temperature comes down to 45°C or lower.
Compressor running but no ice	1.Refrigerant leak 2.Refrigeration system is blocked; 3. Magnetic solenoid valve faulty 4.Condenser fan not working 5. Water shortage	1. Check for leaks, recharge refrigerant 2. Add nitrogen into the system and change the filter 3. Change the magnetic solenoid valve 4. Check the condenser fan 5. Check the water supply system (water tap and water inlet pipe)
Compressor not running	1. Ice bin is full 2. Compressor temperature is too high)	Remove some of the ice Stop the machine for 1 hour and restart it

**Note:** Safety protection is set in ice maker, please restart ice maker when there is error. If error is not solved, please contact authorized agent or repair service.

## PART IX

### PROBLEM INDICATOR LIGHT REFERENCE

Item	Display
Water Shortage	Power indicator (red) flashing
Condenser Sensor failure	Ice full indicator (yellow) flashes
Evaporator Sensor failure	Ice making indicator (green) flashes

#### Before call for service

If the ice maker is not working or not working correctly, before calling for service, please check the following:

\* Check to be sure the ice maker is plugged into electrical socket correctly and switch on.

\* Check if the Ice making light on the control panel is ON

\* Check to be sure water supplier is turned on

\* Make sure air filter is clean.

Please contact an authorized service center near you for further service or help.